

SERVICE MANUAL & PARTS LIST (without price)

FX-9700GH (LX-395AH)

MAR. 1995

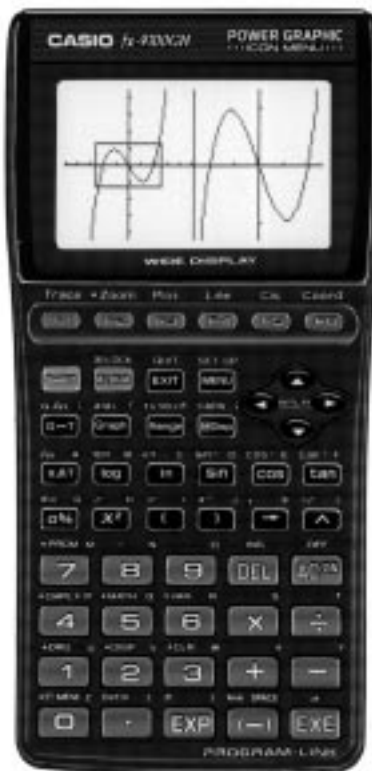

fx-9700GH

CASIO®

CONTENTS

1. SCHEMATIC DIAGRAM	
1-1. Main PCB	1
1-2. Power Supply	2
2. SPECIFICATIONS	3
3. OPERATION CHECK	4
4. DATA TRANSFER CHECK.....	8
5. DATA COMMUNICATIONS	
5-1. Connecting Two fx-9700GE Units	9
5-2. Before Starting Data Communications	9
5-3. Setting Communications Parameters	11
5-4. Using ALL, Range, and Factor	11
5-5. Data Communications Precautions	13
6. PIN FUNCTION.....	14
7. TROUBLESHOOTING.....	15
8. DISASSEMBLY VIEW	16
9. PARTS LIST	21

1. SCHEMATIC DIAGRAM
1-1. Main PCB

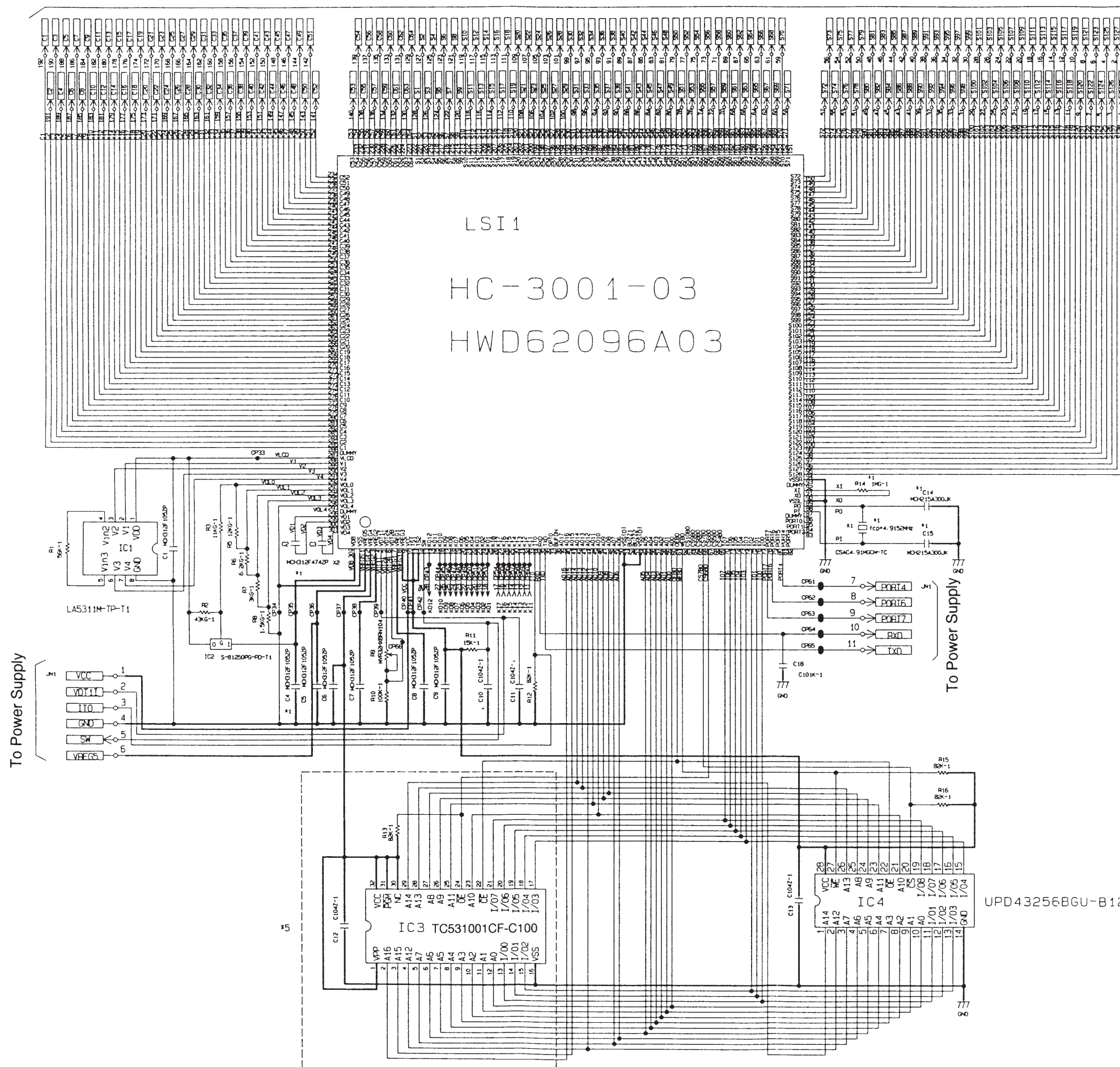

TO LCD

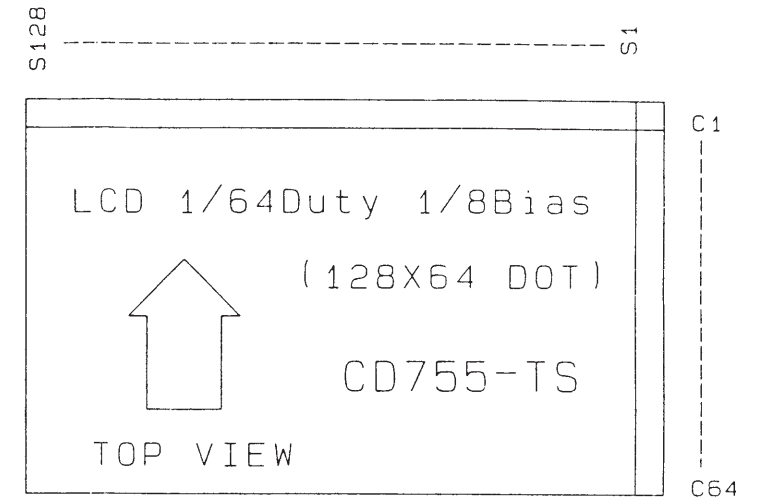

NOTES

- ◆ : Power supply checking points.
- : Function checking points.

1-2. Power Supply

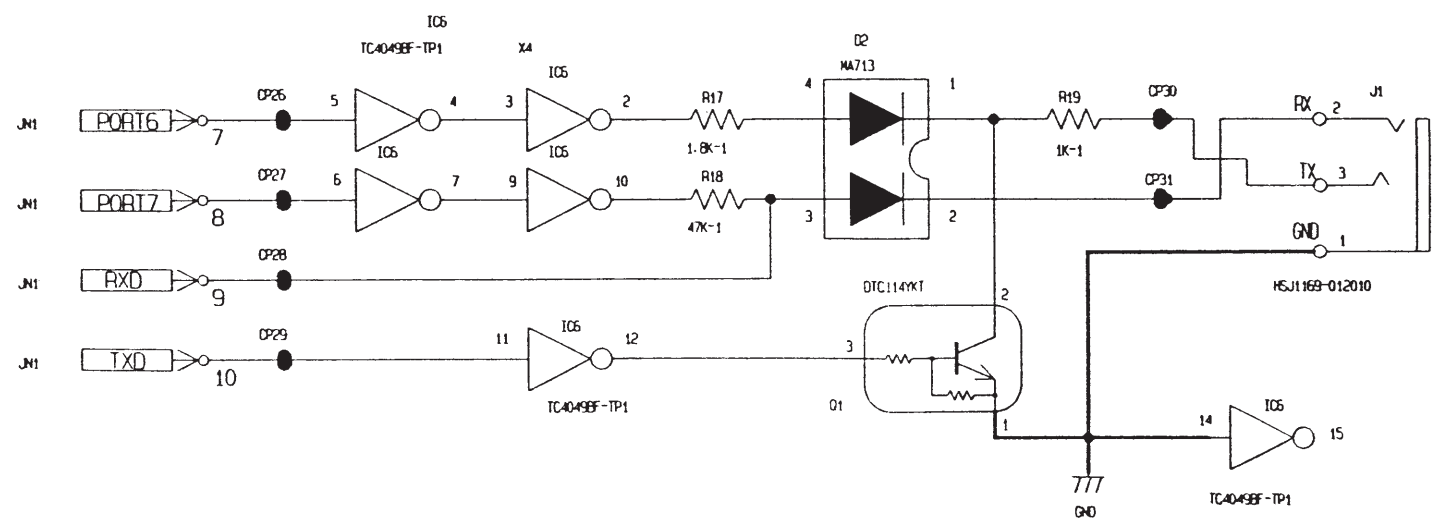
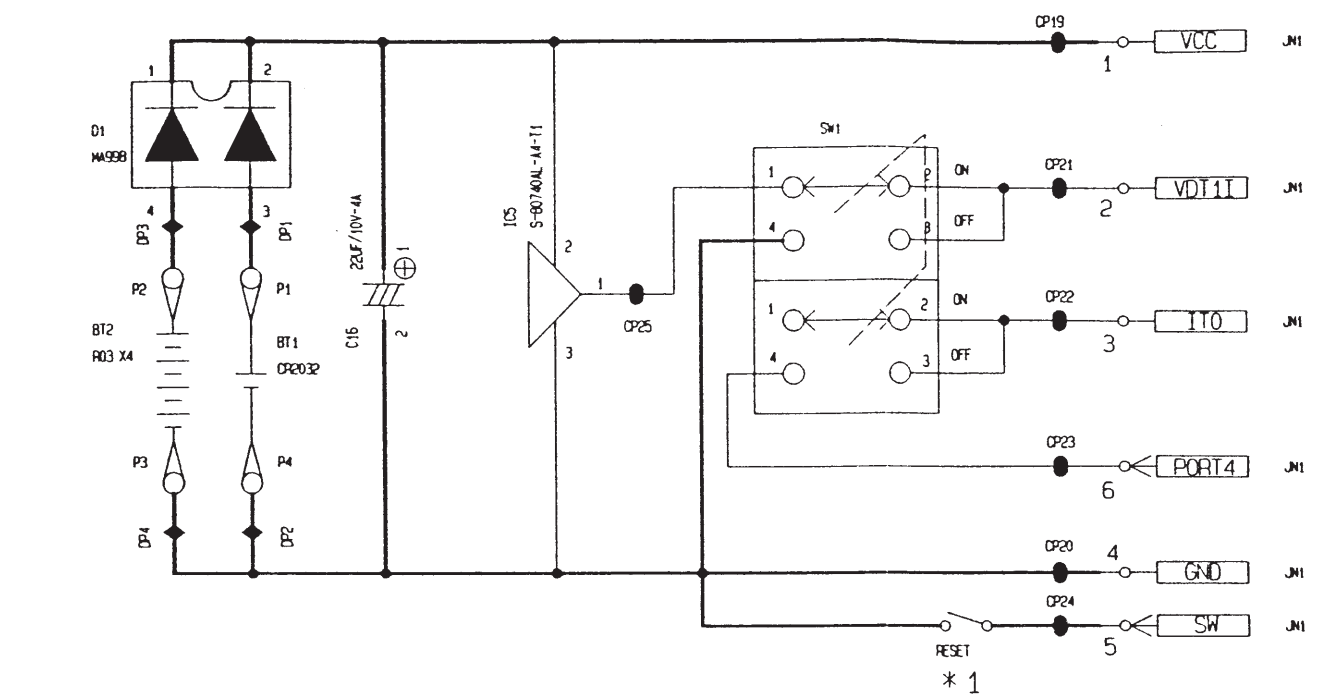
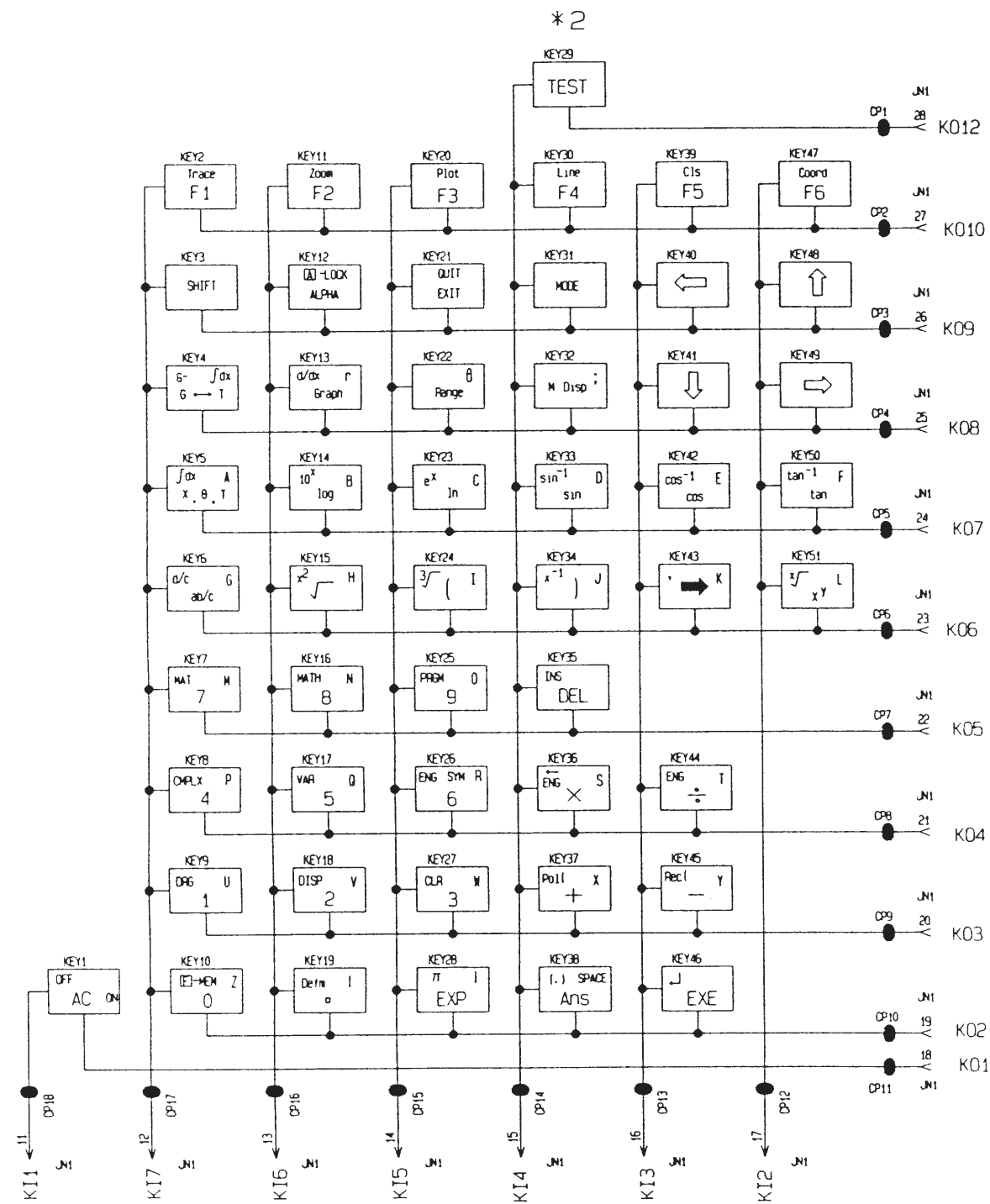

NOTES

- ◆ : Power supply checking points.
- : Function checking points.

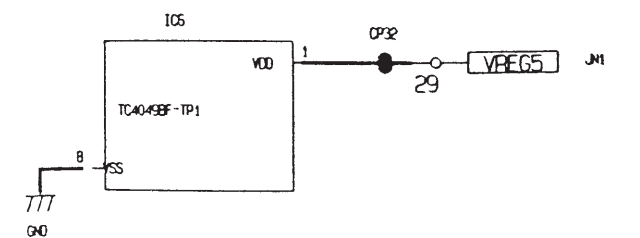

2. SPECIFICATIONS

Display system:	21-character × 8-line liquid crystal display; 12-digit mantissa and 2-digit exponent for calculations; displays binary, octal, hexadecimal, sexagesimal values, fraction, complex number
Power supply:	Main: Four AAA-size batteries (LR03 (AM4) or R03 (UM-4)) Memory protection: One CR2032 lithium battery
Power consumption:	0.1W
Battery life: *	Main: Approximately 650 hours with battery type LR03 (AM4) Approximately 350 hours with battery type R03 (UM-4) Approximately 2 years (power switch off) with LR03 (AM4)/R03 (UM-4) Memory protection: Approximately 15 months

* The batteries that have been installed in this unit when user purchased it had been used in the factory test, so it will be impossible to fully satisfy this specifications when these batteries are used.

Auto power off:

Power is automatically switched off approximately six minutes after last operation except when drawing dynamic graphs.

Ambient temperature range: 0°C ~ 40°C (32°F ~ 104°F)

Dimensions: 20mm H × 85mm W × 172.5mm D (³/₄" H × 3³/₈" W × 6³/₄" D)

Weight: 218.5g (7.7 oz) including batteries

Accessories: Hard case

Current Consumption

	TYP [μA]	MAX [μA]
OFF	————	20.7
ON (MENU)	1430.22	2026.60

3. OPERATION CHECK

NO.	OPERATION	DISPLAY	NOTE
1	Turn the side switch (LOCK) on and push the "RESET" button.	<pre> ***** * RESET * ***** RESET ALL MEMORIES? [YES] RESET ALL [NO] </pre>	
2	[F1]	<pre> ***** * RESET * * ALL MEMORIES! * * * * * * * * * * * * * ***** </pre>	
3	[SHIFT]	<pre> RUN / COMP G-type : RECT / CONNECT angle : Deg display : Norm 1 M-D/Cpy : M-Disp [ZOOM] [PLOT] [LINE] [CLS] </pre>	
4	[AC]	No Display	
5	[F6] [a ^b /c] [AC] Press the above key at the same time.	<pre> *** Lx370 TEST *** 1. TEST MODE 2. Transmit 3. Exit </pre>	
6	[1]	<pre> -- Lx370 TEST MODE -- 1. LCD 2. KEY 3. RAM 4. DET 5. TRS 0. Rst </pre>	

NO.	OPERATION	DISPLAY	NOTE
7	1	FRAME Display	
8	EXE	No Display	
9	EXE	ALL DOT Display	
10	EXE	CHECKER Display	
11	EXE	REVERSE CHECKER Display	
12	EXE	<p>-- Lx370 TEST MODE --</p> <ol style="list-style-type: none"> 1. LCD 2. KEY 3. RAM 4. DET 5. TRS 0. Rst 	

NO.	OPERATION	DISPLAY	NOTE
13	[2]	Trace	
14	Trace [F1] Zoom [F2] [EXP] [(-)]	ZOOM...	Press each key sequentially as it appears on the display.
15	[EXE]	-- Lx370 TEST MODE -- 1. LCD 2. KEY 3. RAM 4. DET 5. TRS 0. Rst	
16	[3]	RAMSIZE 32K bytes	
		RAMSIZE 32K bytes RAM OK	After a few seconds.
17	[EXE]	-- Lx370 TEST MODE -- 1. LCD 2. KEY 3. RAM 4. DET 5. TRS 0. Rst	

NO.	OPERATION	DISPLAY	NOTE
18	<input type="text" value="0"/>	<pre> ***** * RESET * ***** RESET ALL MEMORIES? <input type="text" value="YES"/> RESET ALL <input type="text" value="NO"/> </pre>	
19	<input type="text" value="F1"/>	<pre> ***** * RESET * * ALL MEMORIES! * * * * * * * * * * * * * ***** </pre>	
20	<input type="text" value="SHIFT"/> <input type="text" value="AC"/>	No Display	

4. DATA TRANSFER CHECK

- Turn off both units and connect them by using SB-60.

Function	Display	
	Master	Slave
1) Press the F6 , a^b/c and AC key at the same time.	<p>*** Lx370 TEST ***</p> <p>1. TEST MODE</p> <p>2. Transmit</p> <p>3. Exit</p>	<p>*** Lx370 TEST ***</p> <p>1. TEST MODE</p> <p>2. Transmit</p> <p>3. Exit</p>
2) 1	<p>-- Lx370 TEST MODE --</p> <p>1. LCD</p> <p>2. KEY</p> <p>3. RAM</p> <p>4. DET</p> <p>5. TRS</p> <p>0. Rst</p>	<p>-- Lx370 TEST MODE --</p> <p>1. LCD</p> <p>2. KEY</p> <p>3. RAM</p> <p>4. DET</p> <p>5. TRS</p> <p>0. Rst</p>
3) 5	<p>=== TRANSMIT Check ===</p> <p>1. COM Check</p> <p>2. RANDOM Data Out</p>	<p>=== TRANSMIT Check ===</p> <p>1. COM Check</p> <p>2. RANDOM Data Out</p>
4) 1	<p>0. Self</p> <p>1. Send</p> <p>2. Receive</p>	<p>0. Self</p> <p>1. Send</p> <p>2. Receive</p>
5) Slave: 2 Master: 1	COM END	WAITING
		COM OK 

5. DATA COMMUNICATIONS

This chapter tells you everything you need to know to transfer programs between the fx-9700GH and another CASIO Power Graphic unit (fx-7700GB, fx-7700GE, fx-7700GH, fx-8700GB, fx-9700GE, fx-9700GH), connected with an optionally available SB-62 cable. To transfer data between an fx-9700GH unit and a personal computer, you will need to purchase the separately available CASIO FA-121 Ver. 2.0 Interface Unit. This chapter also contains information on how to use the optional SB-62 cable to connect to a CASIO Label Printer to transfer screen data for printing.

- Though you can transfer programs between the fx-9700GH and another fx-9700GH, an fx-7700GB, an fx-7700GE, an fx-7700GH, an fx-8700GB or fx-9700GE, all of the examples in this manual cover data transfer with another fx-9700GH only.

5-1. Connecting Two fx-9700GH Units

The following procedure describes how to connect two Power Graphic units with an optional SB-62 connecting cable for transfer of programs between them.

To Connect Two fx-9700GH Units

1. Check to make sure that the power of both fx-9700GH units is off.
2. Remove the covers from the connectors of the two Power Graphic units.
 - Be sure you keep the connector covers in a safe place so you can replace them after you finish your program communications.
3. Connect the two units using the SB-62 cable.

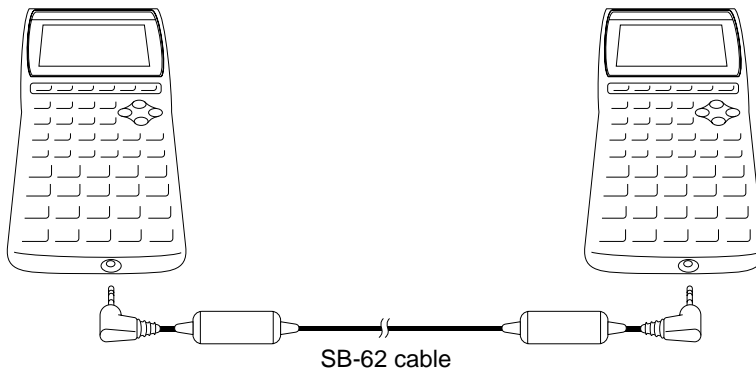

Important

- Keep the connectors of the fx-9700GH covered when you are not using them.

5-2. Before Starting Data Communications

Before actually starting data communications, you should first enter the LINK Mode from the Main Menu.

To Enter the LINK Mode

Highlight the **LINK** icon on the Main Menu.



Press **[EXE]** to display the LINK Mode.

[EXE]

COMMUNICATION

PARITY : EVEN
 BPS : 9600
 F1: TRANSMIT
 F2: RECEIVE
 F3: PARAMETERS

[TRN] **[RCV]** **[PRM]**

[F1] **[F2]** **[F6]**

The following are the operations that can be selected from the function menu at the bottom of the display, Press the function key below the operation you want to perform.

- [F1]** (TRN) Transmit
- [F2]** (RCV) Receive
- [F6]** (PRM) Parameter settings

About the Data Type Selection Screen

Whenever you press **[F1]** (TRN) to send data or **[F2]** (RCV) to receive data, a data type selection screen appears on the display.

Send Unit

[F1] (TRN)

TRANSMIT DATA

▶ ALL

Program

Editor

Function Memory

Matrix

Statistics

Variable Memory

↓

Pointer Indicates more below

Receive Unit

[F2] (RCV)

RECEIVE DATA

▶ ALL

Program

Editor

Function Memory

Matrix

Statistics

Variable Memory

↓

The following table describes what each of these items means. You will learn later how to make a selection using these screens.

Selection	Meaning
ALL	All data from Program to Equation
Program	Program data
Editor	File names and file data
Function Memory	Function memory contents
Matrix	Matrix memory contents
Statistics	Single-variable and paired-variable statistical data
Variable Memory	Value memory and extended memory contents
Range	Graph range parameters
Factor	Factor function zoom ratios
Table	Table & Graph function data
Graph Function	Graph functions
Dynamic Graph	Dynamic Graph function data
Equation	Equation coefficients
Back Up	All memory contents, including mode settings

Note

- If the selections you make on the send unit and receive unit do not match, a TRANSMIT ERROR will be generated on the sender and a RECEIVE ERROR will be generated on the receiver.

5-3. Setting Communications Parameters

Before you can perform data communications, you must first set up certain hardware parameters to make sure that the two units are able to understand each other. The parameters of the sender and the receiver must be identical for them to be able to communicate correctly. There are two hardware parameters that you can set.

Parameter	Settings
PARITY	EVEN
	ODD
	NONE
Speed (BPS)	1200
	2400
	4800
	9600

To Set fx-9700GH Parameters

Starting from the LINK Mode:

F6 (PRM)

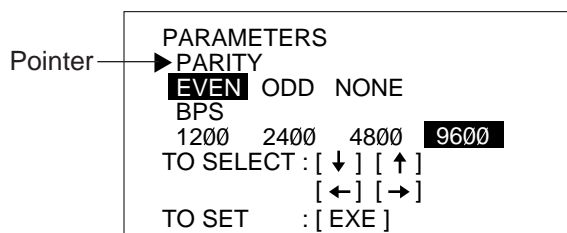

* The parameters that are currently set are highlighted on the display.

The pointer indicate which parameter you can change. Use ◀ and ▶ to move the highlighting and change the parameter where the pointer is located.

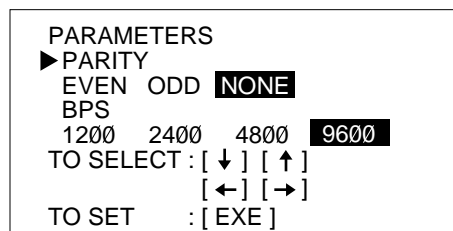

Use ▲ and ▼ to move the pointer up and down.

After the parameters and highlighted the way you want, press **EXE** to store them.

EXE

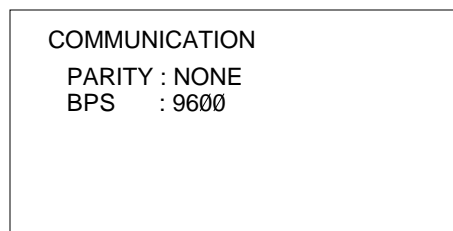

- To abort the parameter setting procedure and return the settings to what they were before you changed them, press **AC** before pressing **EXE** to store the parameters.

5-4. Using ALL, Range, and Factor

The following procedures show how to send data using ALL, Range, and Factor from one fx-9700GH unit to another. The example procedure shows an operation using ALL only, but the procedures for Range and Factor are identical.

• To send data using ALL

Send Unit

Starting from the LINK Mode, press the function key to enter the send mode.

F1 (TRN)

```

TRANSMIT DATA
▶ ALL
Program
Editor
Function Memory
Matrix
Statistics
Variable Memory
    
```

Make sure that the pointer is located at ALL, and press **EXE** to specify it as the data type.

EXE

```

== TRANSMIT ==
ALL

YES          NO
[F1]        [F6]
    
```

Press **F1** (YES) to start the send operation, or **F6** (NO) to abort without sending anything.

F1 (YES)

```

== TRANSMITTING ==

ALL DATA

TO STOP :[ AC ]
    
```

* Pressing **AC** interrupts the send operation and returns to the LINK Mode.

The following appears after the send operation is complete.

```

COMMUNICATION
COMPLETE
ALL DATA

PRESS [ AC ]
    
```

* Press **AC** to return to the LINK Mode.

Warning!

Transferring data using ALL causes data in the applicable memory areas of the receiving unit to be replaced by the received data. Make sure that you do not need the data stored in the receiving unit before you start an operation using ALL.

Receive Unit

Starting from the LINK Mode, press the function key to enter the receive mode.

F2 (RCV)

```

RECEIVE DATA
▶ ALL
Program
Editor
Function Memory
Matrix
Statistics
Variable Memory
    
```

Make sure that the pointer is located at ALL, and press **EXE** to specify it as the data type.

EXE

```

== RECEIVE ==
ALL

YES          NO
[F1]        [F6]
    
```

Press **F1** (YES) to start the receive operation, or **F6** (NO) to abort without receiving anything.

F1 (YES)

```

== RECEIVING ==

ALL DATA

TO STOP :[ AC ]
    
```

* Pressing **AC** interrupts the receive operation and returns to the LINK Mode.

The following appears after the receive operation is complete.

```

COMMUNICATION
COMPLETE
ALL DATA

PRESS [ AC ]
    
```

5-5. Data Communications Precautions

Note the following precautions whenever you perform data communications.

- A TRANSMIT ERROR occurs whenever you try to send data to a receiving unit that is not yet standing by to receive data. When this happens, press **AC** to clear the error and try again, after setting up the receiving unit to receive data.
- A RECEIVING ERROR occurs whenever the receiving unit does not receive any data approximately six minutes after it is set up to receive data. When this happens, press **AC** to clear the error.
- A TRANSMIT ERROR or RECEIVE ERROR occurs during data communications if the cable becomes disconnected, if the parameters of the two units do not match, or if any other communications problem occurs. When this happens, press **AC** to clear the error and correct the problem before trying data communications again. In this case, any data received before the problem occurred is cleared from the receiving unit's memory.
- A MEMORY FULL operation occurs if the receiving unit memory becomes full during data communications. When this happens, press **AC** to clear the error and delete unneeded data from the receiving unit to make room for the new data, and then try again.

6. PIN FUNCTION

CPU (HWD62096A03)

Pin No.	Pin Name	Input / Output	Function
1	VSS		Power supply for LSI, GND
2	VREG5		Regulator power, +5V
3	VREG4		Regulator power for ROM, +3V
4	VREG2		Regulator power, +2V
5	VDT1I	I	Terminal for detector (All off)
6	VDT2A	O	Terminal for detector (Lower battery)
7	VDT2b	I	Terminal for detector (Lower battery)
8	VREG1		Regulator power, +3.2V
9	VREG3		Regulator power for RAM, +3V
10	VCC		Power supply for LSI, +6V
11,12	TS1,TS2	I	Terminal for test
13	SW	I	Reset switch
14~25	KO1~KO12	O	Terminal for key output
26~33	KI1~KI8	I	Terminal for key input
34	ITO	I	Terminal for interrupt
35	RXD	I	Terminal for communication
36	TXD	O	Terminal for communication
37	OPTO	O	Output terminal
38	BUFON	O	Output terminal
39~50	AO6~AO17	O	Address bus
51	VSS		Power supply for LSI, GND
52,53	BZZ1,BZZ2	O	Terminal for buzzer
54	VSS		Power supply for LSI, GND
55~60	AO0~AO5	O	Address bus
61	OEBO	O	Output enable terminal
62	WEBO	O	Write enable terminal
63~69	CS4BO~CS10BO	O	Chip selector terminal
70~77	IO0~IO7	I/O	Data bus
78~85	PORT0~PORT7	I/O	Input/output port
86	DUMMY		Dummy terminal
87,88	PI,PO		Power for ceramic oscillator
89	VSSL		Power supply for LSI, GND
90,91	XO,XI		Power
92	DUMMY		Dummy terminal
93	VSSR		Power supply for LSI, GND
94~221	S1~S128	O	Terminal for LCD
222~285	C1~C64	O	Terminal for LCD
286	DUMMY		Dummy terminal
287	VLCD		Power supply for LCD, +12V
288~291	V1~V4		Power supply for LCD bias
292~296	VOL0~VOL4		Power supply for LCD contrast
297	DUMMY		Dummy terminal
298~301	VD1~VD4		Power for doubler
302	VDB		Power for doubler, +12V

7. TROUBLESHOOTING

SYMPTOM	CAUSE	SOLUTION
Intermittent display	Dirt or poor contact on battery	Clean or adjust pressure of contact
	Poor contact on power switch	Clean or replace power switch
	Poor connection on PC joiner	Resolder or replace
	Poor soldering on LSI, capacitor, or resistor	Resolder
No display at all	Weak battery	Replace battery
	Dirt or poor contact on battery	Clean or adjust pressure of contact
	Poor contact on power switch	Clean or replace power switch
	Poor connection on PC joiner	Resolder or replace
	Defective LSI, capacitor, or resistor	Replace
Erratic display	Poor contact between LCD and PCB	Replace the heat seal
	Poor soldering on LSI	Resolder or replace display PCB ass'y
Certain key does not function	Dirt on key contact	Clean or replace contact
	Heavy key motion	Clean or replace the key
	Poor soldering on LSI	Resolder
	Defective LSI, capacitor, or resistor	Replace
All keys do not function	Constant contact is made on a certain key	Separate the contact
	Defective LSI, capacitor, or resistor	Replace
Heavy key motion	Dirt or scratch on the key	Clean or replace the key

8. DISASSEMBLY VIEW

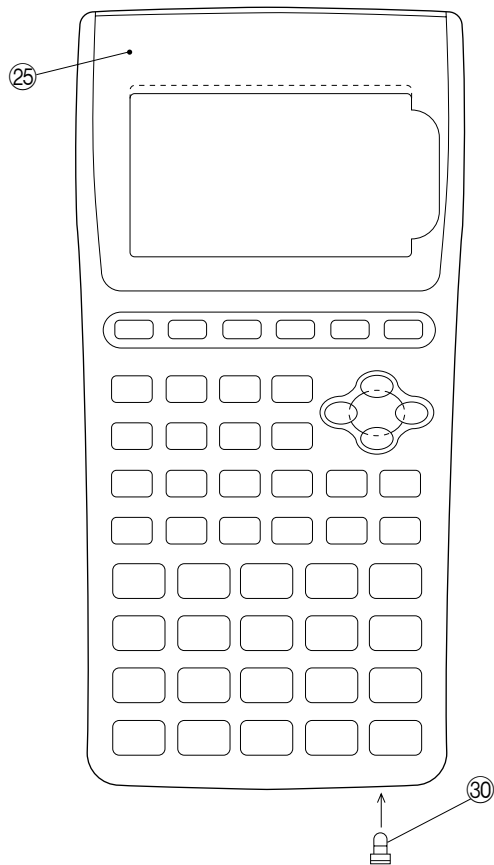
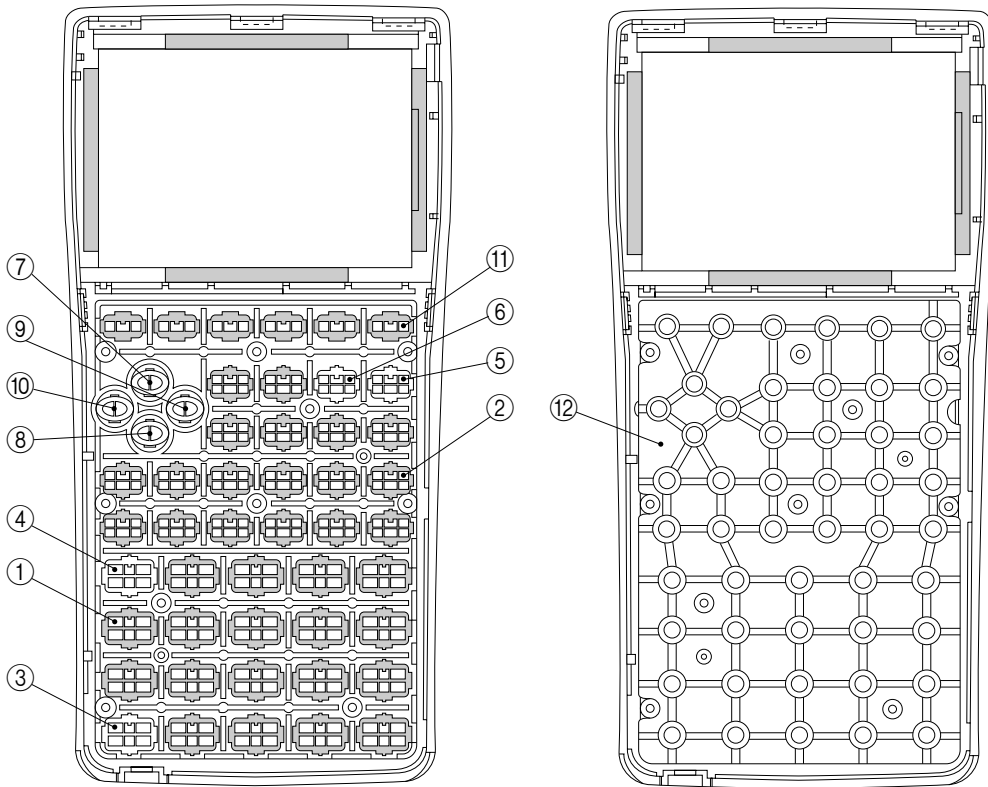

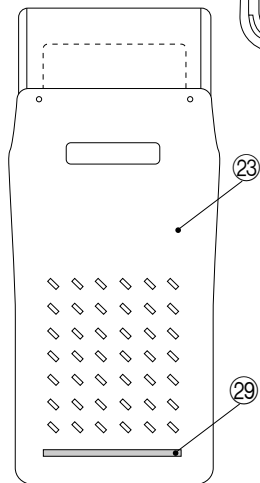
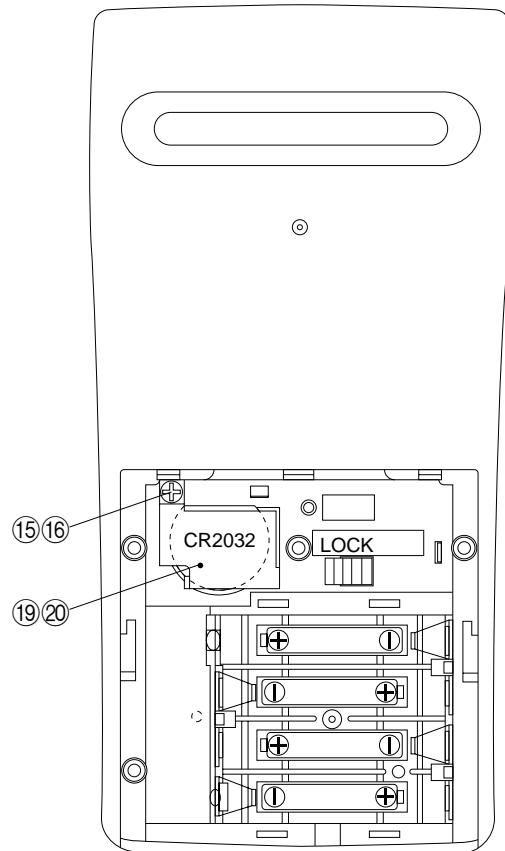
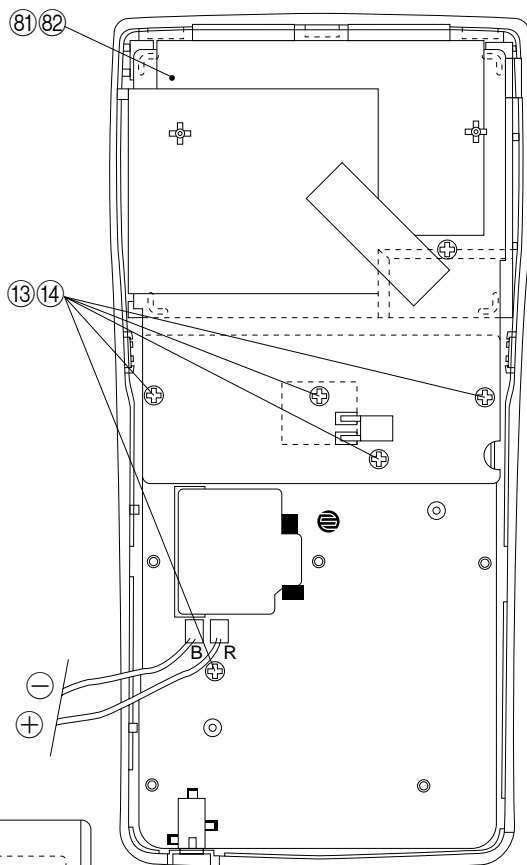
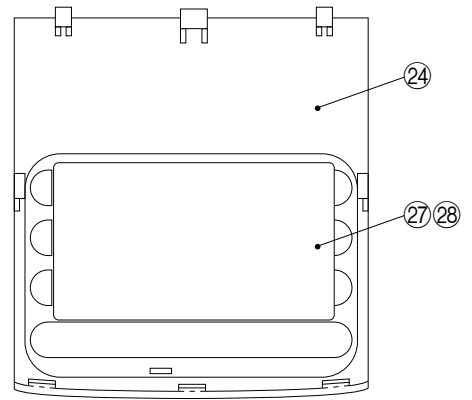
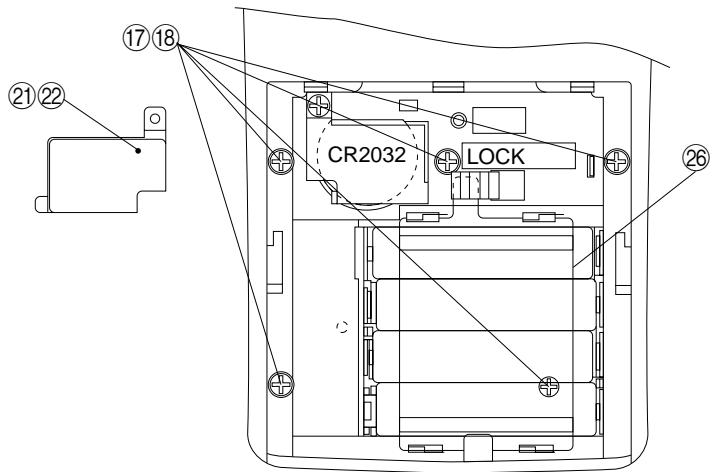

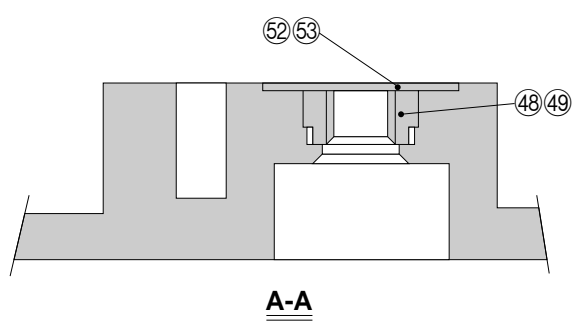
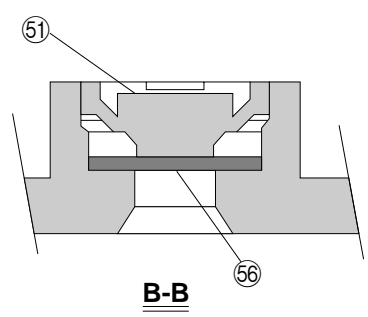
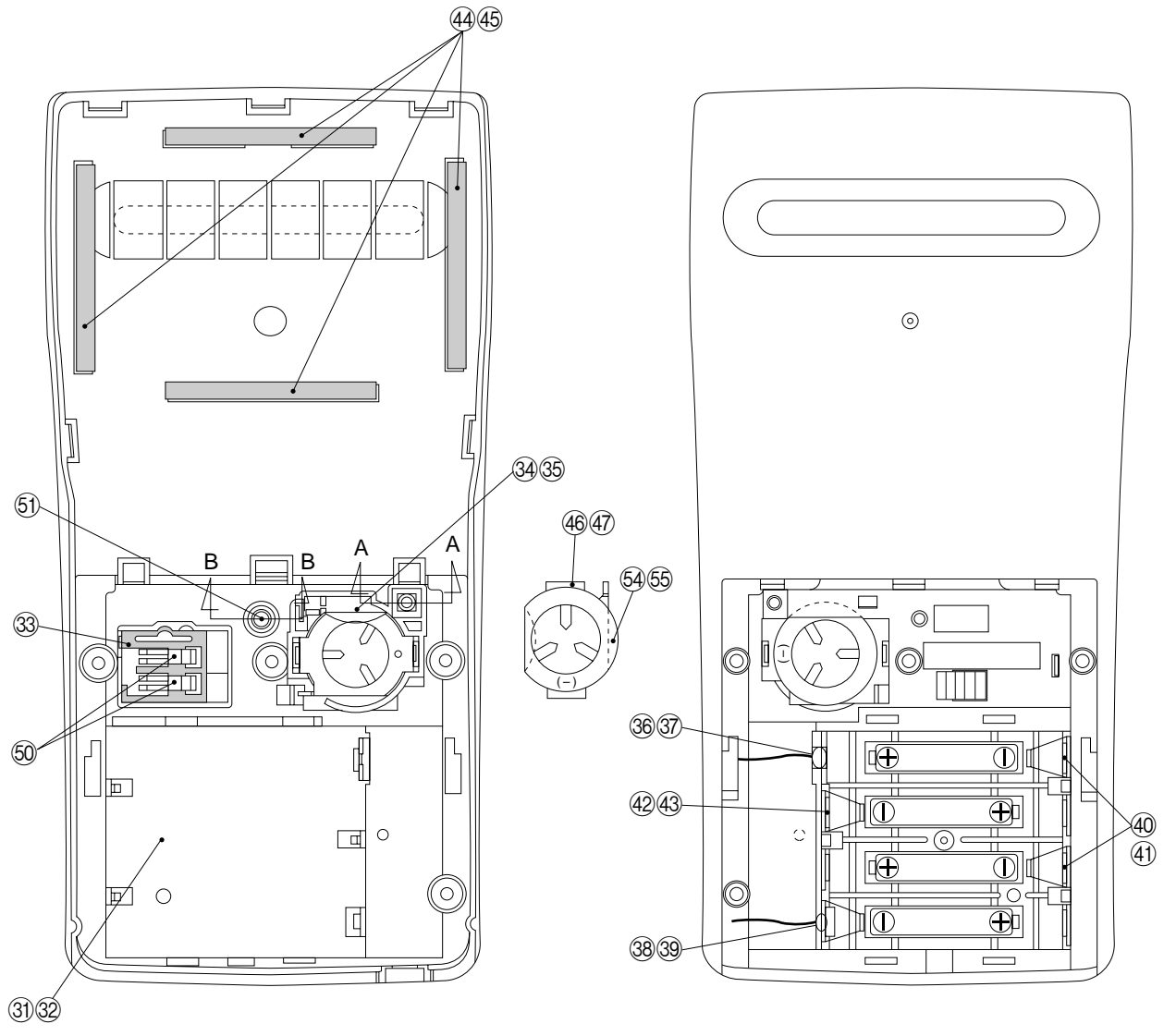

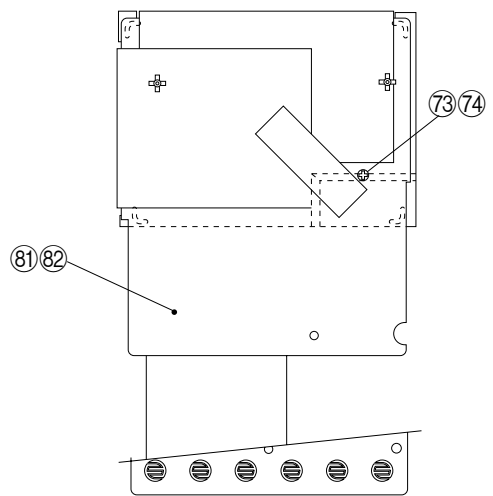
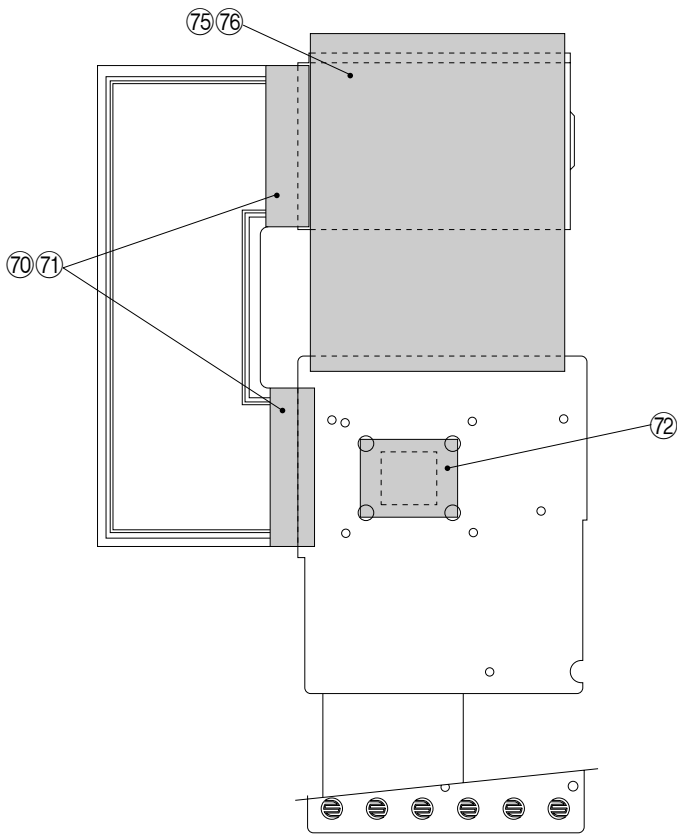
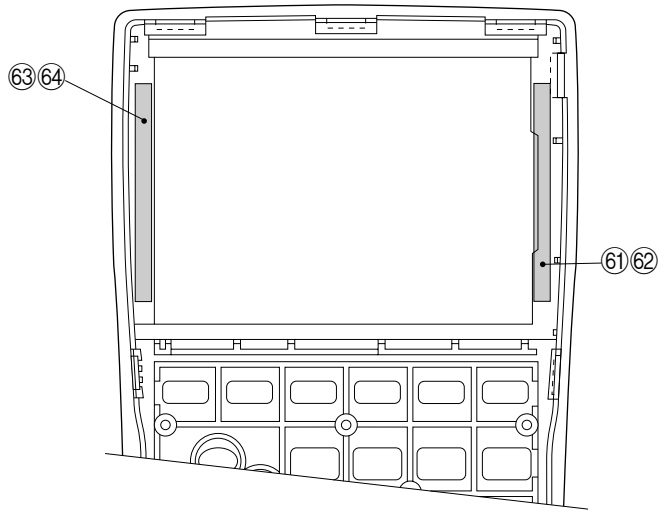
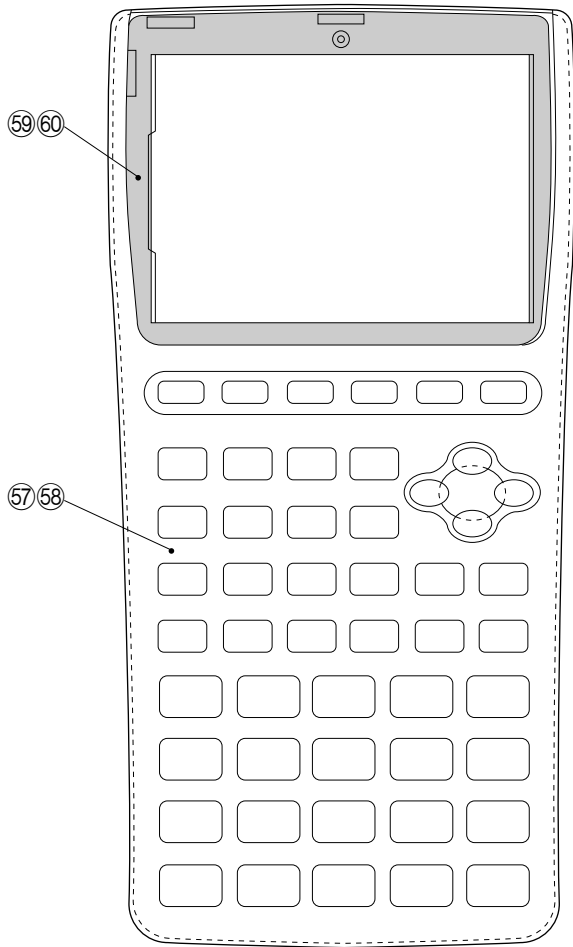

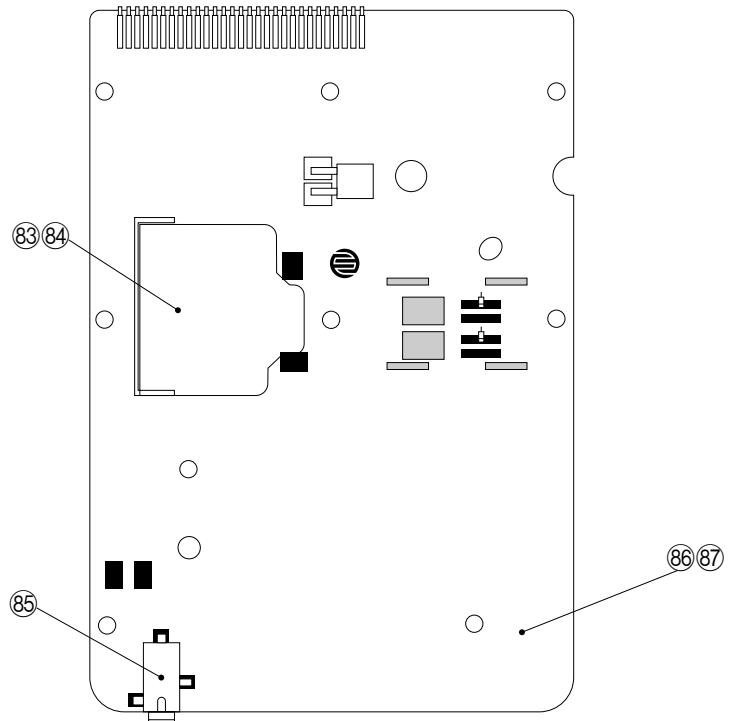
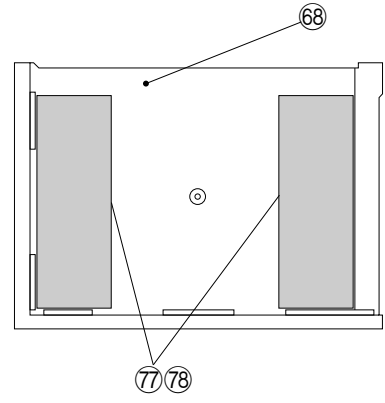
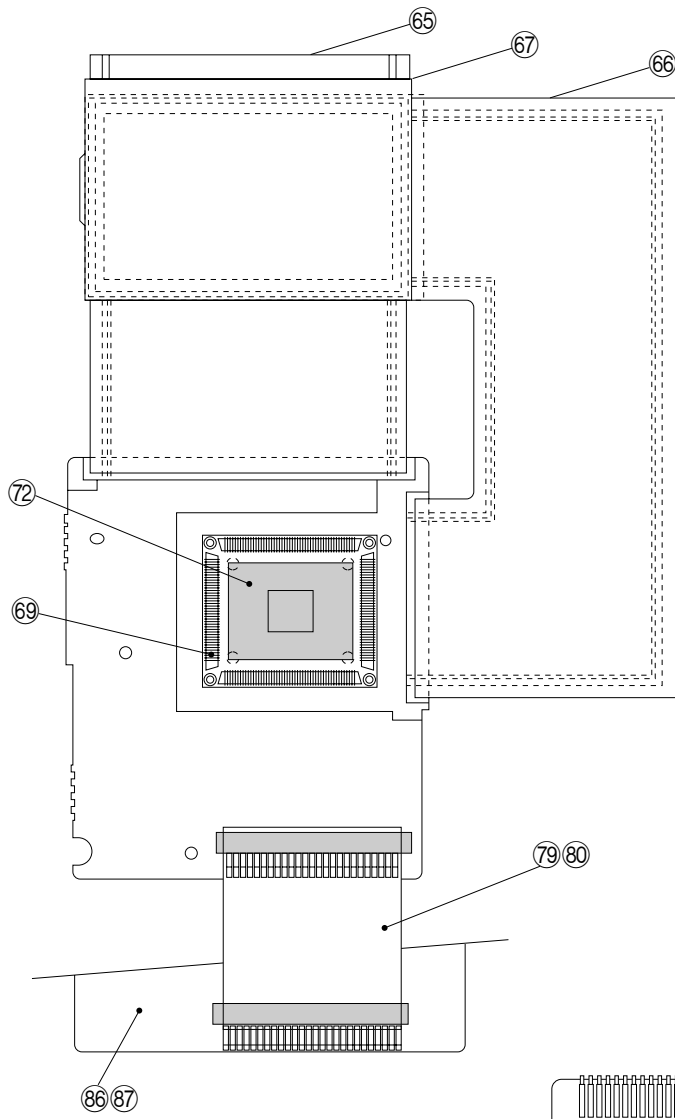

9. PARTS LIST

N	Item	Code No.	Parts Name	Specification	Q	M	FOB Japan N.R.Yen Unit Price	R
COMPONENTS								
	1	6407 9860	Button A-L370	A211169-1	1	10		C
	2	6407 9920	Button B-L370	A211316-1	1	10		C
	3	6408 0030	Button C-L370	A312937-1	1	20		C
	4	6407 9870	Button D-L370	A211172-1	1	20		C
	5	6408 0070	Button E-L370	A313257-1	1	20		C
	6	6408 0080	Button F-L370	A313257-2	1	20		C
	7	6408 0000	Button G-L370	A311693-9	1	20		C
	8	6407 9970	Button H-L370	A311693-10	1	20		C
	9	6407 9980	Button I-L370	A311693-11	1	20		C
	10	6407 9990	Button J-L370	A311693-12	1	20		C
	11	6408 0020	Button K-L370	A312914-1	1	10		C
	12	6407 9880	Key contact rubber L370	A211181-1	1	5		C
	13	6407 9930	Flat screw A-L370	A310044-41	5	50		C
	15	6405 8860	Decoration screw C-L373	A412299-6	1	50		C
	17	6407 9940	Flat screw C-L370	A310044-43	5	50		C
	19	6407 9961	Battery cover L375	A310945A-3	1	10		C
	21	6405 8780	Tape E-L373	A411085-3	1	10		X
	23	6407 9900	Hard case L370	A211187-1	1	5		C
	24	6407 9910	Battery cover L370	A211188-1	1	20		C
N	25	6413 5800	Display plate L370	A312942-3	1	5		C
	26	6408 0060	Battery holder L370	A312944-1	1	20		C
N	27	6408 9920	Label A-L370AHQ	A413640-3	1	20		X
	29	6408 0220	Rubber foot L375	A413646-1	1	20		X
	30	6390 0431	Cap V332	A310765A-1	1	10		B
LOWER CASE ASS'Y								
	31	6407 9850	Lower case L370	A110736-1	1	1		C
	33	6408 0040	Switch knob L370	A312941-1	1	20		C
	34	6408 0010	Battery spring A-L375	A311808-3	1	10		C
	36	6407 9950	Battery spring B-L375	A310154-3	1	10		C
	38	6408 0100	Battery spring A-L370	A410112-3	1	20		C
	40	6408 0110	Battery spring B-L370	A410113-3	2	10		C
	42	6408 0120	Battery spring L370	A412218-2	1	10		C
	44	6408 0170	Cushion A-L370	A413632-1	4	20		C
	46	6408 0091	Battery spring A-L375	A33938-3	1	20		C
	48	6405 9260	Nut L373	A411430-3	1	20		X
	50	6274 7023	Contact spring	A4532C-1	2	10		C
	51	6391 8831	Reset key V160	A311024A-1	1	20		C
	52	6405 9250	Insuration seal L373	A413730-1	1	10		X
	54	6405 9240	Battery insuration plate L373	A413729-1	1	10		C
	56	6405 6440	Blind L171	A413625-1	1	10		C
UPPER CASE ASS'Y								
	57	6407 9840	Upper case L370	A110735-1	1	1		C
	59	6408 0140	Adhesive tape A-L370	A413594-1	1	10		C
	61	6408 0170	Cushion A-L370	A413632-1	1	20		C
	63	6408 0180	Cushion B-L370	A413633-1	1	20		C
L370-1 ASS'Y								
	65	5610 7640	Heat seal A-L370	A312896-1	1	1		A
	66	5610 7650	Heat seal B-L370	A312898-1	1	1		A
	67	3335 4375	LCD	CD755-TS	1	1		A
	68	6407 9890	LCD holder L370	A211185-1	1	20		C
	69	6408 0271	COF3001-F1 sub ass'y	A313284A*1	1	1		B

Notes: N – New parts
M – Minimum order/supply quantity
R – Rank
Q – Quantity used per unit

R – A : Essential
B : Stock recommended
C : Others
X : No stock recommended

N	Item	Code No.	Parts Name	Specification	Q	M	FOB Japan N.R.Yen Unit Price	R	
N	70	6408 0150	Tape A-L370	A413596-1	2	20		X	
	72	6403 9331	Tape C-L170	A413108A-1	2	10		X	
	73	6407 9930	Flat screw A-L370	A310044-41	1	50		C	
	75	6408 0190	Tape B-L370	A413639-1	1	20		X	
	77	6405 9110	Adhesive tape C-L373	A412118A-2	2	20		C	
	79	6408 0210	PC joiner L370	A413642-1	1	10		C	
	IC1	2189 2009	Linear IC	LA5311M-TP-T1	1	1		C	
	IC2	2105 1533	CMOS IC	RH5RA50AA-T1	1	1		C	
	IC3	2011 9891	LSI	TC531001CF-C100	1	1		B	
	IC4	2011 3955	LSI	UPD43256BGU-B12	1	1		B	
	X1	2590 1561	Ceramic oscillator	CSTC4.91MGCM-TC	1	5		C	
	R1	2792 0756	Chip resistor	MCR10EZHZ563	1	20		C	
	R2	2795 3213	Chip resistor	MCR10EZHZG513	1	20		C	
	R3	2795 3836	Chip resistor	MCR10EZHZG203	1	20		C	
	R5	2795 0693	Chip resistor	MCR10EZHZG123	1	20		C	
	R6	2795 3269	Chip resistor	MCR10EZHZG622	1	20		C	
	R7	2795 2443	Chip resistor	MCR10EZHZG302	1	20		C	
	R8	2795 3339	Chip resistor	MCR10EZHZG152	1	20		C	
	R9	3122 2009	Chip volume	MVR32HXBRN104	1	10		C	
	R10	2792 0209	Chip resistor	MCR10EZHZJ104	1	20		C	
	R11	2792 0845	Chip resistor	MCR10EZHZJ153	1	20		C	
	R12,13,15,16	2795 0273	Chip resistor	MCR10EZHZJ823	4	20		C	
	R14	2795 0525	Chip resistor	MCR10EZHZG105	1	20		C	
	C1,C4~9	2845 1925	Chip capacitor	MCH312F105ZP	7	10		C	
	C2,C3	2845 3486	Chip capacitor	MCH312F474ZP	2	10		C	
	C10~13	2845 1540	Chip capacitor	MCH212F104ZK	4	20		C	
	C14,15	2845 2499	Chip capacitor	MCH215A300JK	2	20		C	
	C18	2845 1547	Chip capacitor	MCH215A101JK	1	20		C	
	86	6408 8020	PCB L370-2 Ass'y	A211346A*1	1	1		B	
	N	81	6414 1890	PCB L370-1 Ass'y	A110886F*3	1	1		B
	L370-2 ASS'Y								
	83	6408 0160	Tape C-L370	A413597-1	1	20		X	
	85	3501 6538	Miniature jack	HSJ1169-012010	1	5		X	
	C16	2805 8700	Electrolytic capacitor	ECE-A1AKA2201	1	20		C	
	IC5	2105 3206	CMOS IC	RH5VL40CA-T1	1	10		C	
	IC6	2101 0952	CMOS IC	TC4049BF-TP1	1	1		C	
	Q1	2259 0959	Chip digital transistor	DTC114YKT-146	1	20		C	
	D1	2390 1407	Chip diode	MA998-(TX)	1	10		C	
	D2	2390 0364	Schottky diode	MA713-TX	1	10		C	
	R17	2792 1191	Chip resistor	MCR10EZHZJ182	1	20		C	
	R18	2792 0462	Chip resistor	MCR10EZHZJ473	1	20		C	
	R19	2792 0470	Chip resistor	MCR10EZHZJ102	1	20		C	
	86	6408 8020	PCB L370-2 Ass'y	A211346A*1	1	1		B	
OTHERS									
N		6414 1830	EMI Label Z556	A440515-1	1	20		X	
N		6411 7670	Label B-L370AHW	A415138-2	1	20		X	
N		6411 7660	Label B-L370AHQ	A415138-1	1	20		X	
N		6412 2020	Label D-L370AHQ	A414829-2	1	20		X	
N		6414 2260	Label C-L370AHQ	A440517-1	1	20		X	

Notes: N – New parts
M – Minimum order/supply quantity
R – Rank
Q – Quantity used per unit

R – A : Essential
B : Stock recommended
C : Others
X : No stock recommended

CASIO COMPUTER CO.,LTD.
Service Division

8-11-10, Nishi-Shinjuku
Shinjuku-ku, Tokyo 160, Japan
Telephone: 03-3347-4926